

	MAX. ENGINE POWER	MAX. BACKHOE DIG DEPTH	MAX. LOADER CAPACITY
3CX ECO	55kW (74hp) or 68kW (91hp)	4.75 metres	1.0m <sup>3</sup>
3CX ECO SITEMASTER	55kW (74hp) or 68kW (91hp)	5.97 metres	1.2m <sup>3</sup>
3CX ECO CONTRACTOR	81kW (109hp)	5.97 metres	1.2m <sup>3</sup>

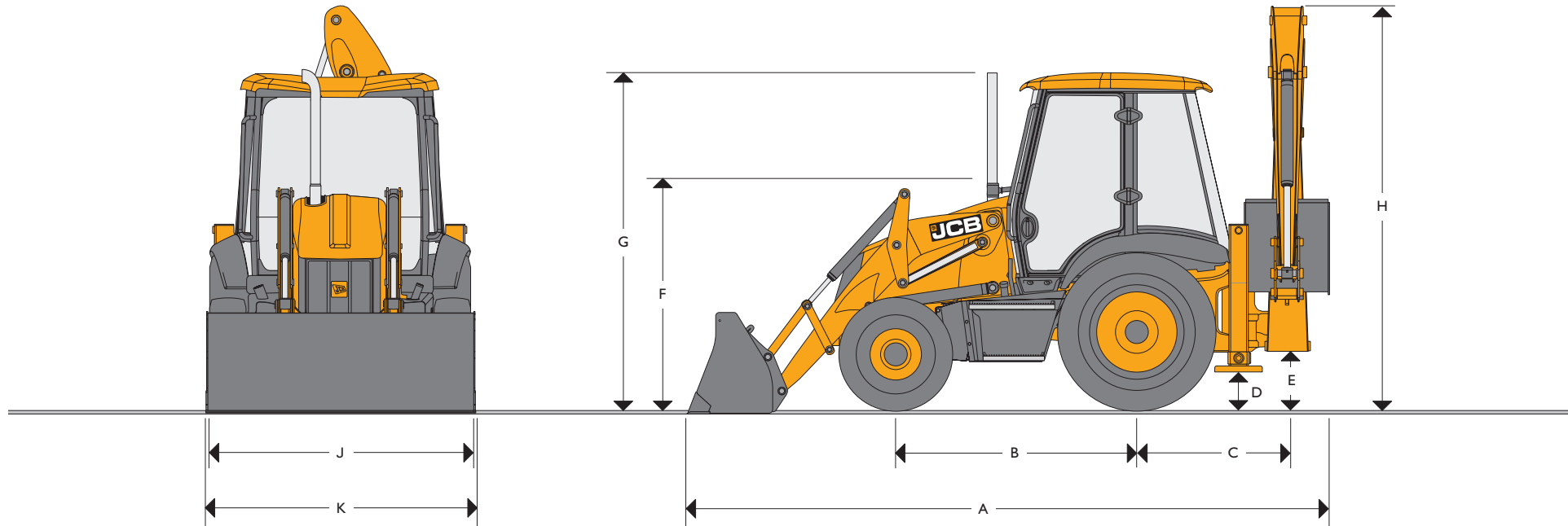

### STATIC DIMENSIONS

JCB Backhoe Loaders feature heavy duty one piece mainframe, componentised driveline and fully enclosed engine compartment. All fluid and component compartments are lockable using the ignition key.

Machine model	3CX Eco	3CX Eco Sitemaster	3CX Eco Contractor
	m	m	m
A Total travel length	5.62	5.62	5.62
B Axle centreline distance	2.17	2.17	2.17
C Slew centre to rear axle centre distance	1.36	1.36	1.36
D Stabiliser feet clearance	0.37	0.37	0.37
E Kingpost clearance	0.52	0.52	0.52
F Steering wheel centre height	1.94	1.94	1.94
G Cab roof height	3.03	3.03	3.03

Machine model	3CX Eco	3CX Eco Sitemaster	3CX Eco Contractor
	m	m	m
H Total travel clearance	3.61	3.61	3.61
J Rear frame width	2.35	2.24*	2.35
K Shovel width	2.35	2.23*	2.35

\* Narrow option

	MAX. ENGINE POWER	MAX. BACKHOE DIG DEPTH	MAX. LOADER CAPACITY
3CX ECO SUPER	68kW (91hp)	4.72 metres	1.2m <sup>3</sup>
3CX ECO SUPER SITEMASTER	68kW (91hp)	5.93 metres	1.2m <sup>3</sup>

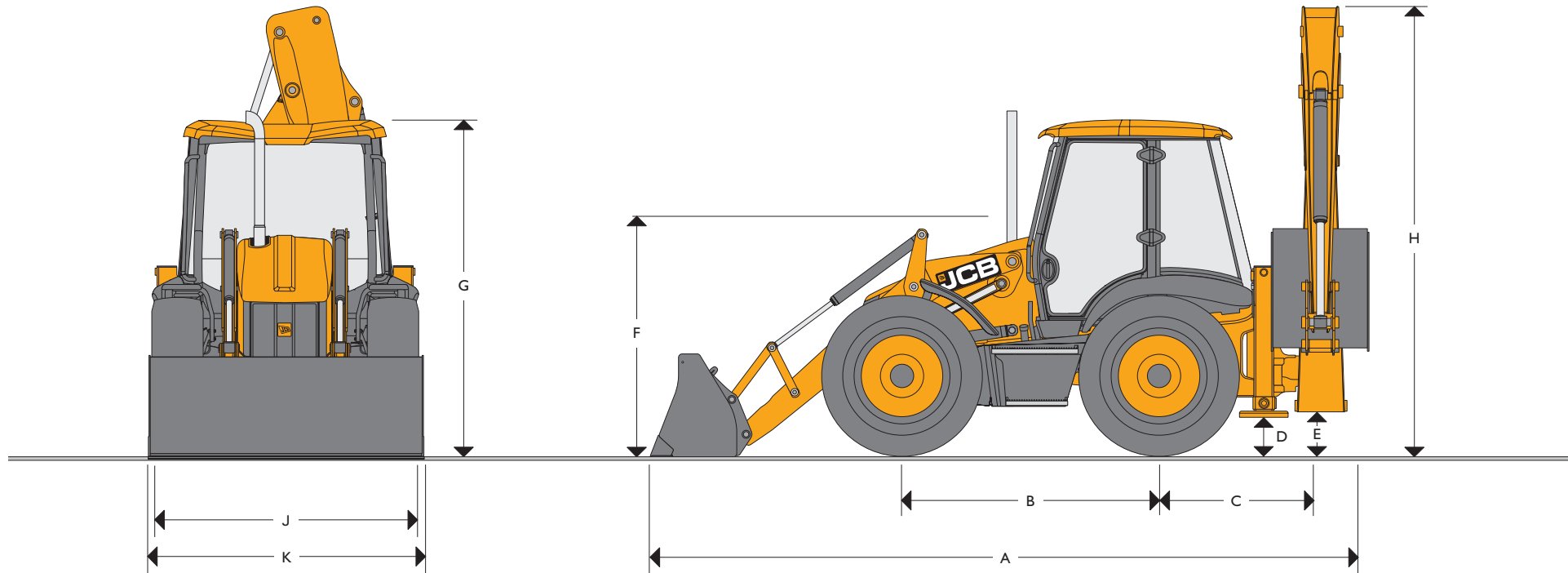

### STATIC DIMENSIONS

JCB Backhoe Loaders feature heavy duty one piece mainframe, componentised driveline and fully enclosed engine compartment. All fluid and component compartments are lockable using the ignition key.

Machine model	3CX Eco Super	3CX Eco Super Sitemaster
	m	m
A Total travel length	5.91	5.91
B Axle centreline distance	2.22	2.22
C Slew centre to rear axle centre distance	1.36	1.36
D Stabiliser feet clearance	0.33	0.33
E Kingpost clearance	0.48	0.48

Machine model	3CX Eco Super	3CX Eco Super Sitemaster
	m	m
F Steering wheel centre height	1.86	1.86
G Cab roof height	2.98	2.98
H Total travel clearance	3.48	3.56
J Rear frame width	2.24	2.24
K Shovel width	2.23	2.23

### GROUND LINE ANGLES

#### 3CX Super, 3CX Super Sitemaster

- A Approach angle 74°
- B Interference angle/ramp to ground plane 118°
- C Departure angle 19°

#### 3CX, 3CX Contractor, 3CX Sitemaster

- A Approach angle 66°
- B Interference angle/ramp to ground plane 120°
- C Departure angle 20°

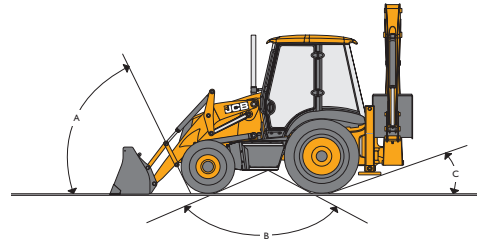

### OPERATING WEIGHTS

Operating weight to ISO 6016 includes machine with 6 in 1 shovel, 610mm excavator bucket, full fuel tank and operator.

Machine model	3CX	3CX Sitemaster	3CX Contractor	3CX Super	3CX Super Sitemaster
	kg	kg	kg	kg	kg
Standard dipper	7751	–	–	8051	–
Extending dipper	8136	8136	8136	8436	8436

### ENGINE SUPPORT SYSTEM

Engine support system is designed for ease of daily checks, routine maintenance and longer service intervals.

<b>Fuel type</b>	Diesel.
<b>Fuel filter</b>	Replaceable cartridge plus water/sediment separator prefilter.
<b>Air cleaner</b>	Dual, dry element type with self cleaning internal air intake pre-cleaner.
<b>Oil filter and lubrication</b>	Full flow, spin-on type filter.
<b>Cooling system</b>	Hot climate specification, pressurised 1.0 bar suction fan. Pressurised recovery tank with integral filler neck.

### ENGINE (Stage IIIB Emissions)

The JCB Ecomax engine is so efficient that it complies with Stage IIIB/Tier 4i without the need for exhaust after-treatment systems; Diesel Particulate Filter (DPF) or Selective Catalytic Reduction (SCR). This is because its high pressure common rail combustion system, produces virtually no particulate matter in its exhaust gases.

High Pressure Common Rail Fuel Injection – Injects fuel at high pressure, up to 2000 bar, with extremely precise control.

Variable Geometry Turbo Charger (VGT) – Allows precise control of the quantity of air entering the engine, to match the fuel injected in order to optimise combustion efficiency.

Exhaust Gas Recirculation (EGR) – is a controlled recirculation of a portion of exhaust gases back into the combustion chamber, reducing NOx emissions.

Machine models	3CX 3CX Sitemaster	3CX, 3CX Sitemaster, 3CX Super, 3CX Super Sitemaster	3CX Contractor
Manufacturer	JCB	JCB	JCB
Aspiration	Turbocharged	Turbocharged	Turbocharged & Intercooled
Displacement	4.4 Ltr	4.4 Ltr	4.4 Ltr
No. of cylinders	4	4	4
Bore	mm 103	103	103
Stroke	mm 132	132	132
Rated engine RPM	2200	2200	2200
<b>Power ratings</b>			
Rated ISO 14396 (SAE J1995 Gross)	kW (HP) 55 (74)	68 (91)	81 (109)
<b>Maximum torque</b>			
Rated ISO 14396 (SAE J1995 Gross)	Nm 400	433	516
Max. torque RPM	1200	1400	1500

### ELECTRICAL AND INSTRUMENTATION

12 volt negative ground, utilising wiring and connectors meeting IP69 water ingress test standard. Central fuse panel.

<b>Gauges</b>	Tachometer, engine coolant temp, fuel level, hourmeter, clock.
<b>Warning system</b>	Audible and visual system for engine oil, water in fuel, transmission oil temperature and pressure, park brake, air cleaner, alternator.
<b>Battery</b>	900 CCA/110 A/hr.
<b>Pre-wire</b>	Radio speakers (cab), beacon (all).
<b>Horn</b>	Controlled from both front and rear.
<b>Alternator</b>	95 amp standard.
<b>Front working lights</b>	4 adjustable.
<b>Rear working lights</b>	4 adjustable.

## TRANSMISSION

The JCB Transmissions are designed and built specifically for JCB Backhoe Loaders. They feature synchronised shifting in all gears. Powershuttle between forward and reverse. Ground speeds are designed to maximise productivity.

Optional JCB 6-speed autoshift transmission features automatic upshift and downshift between 4th, 5th and 6th gear controlled by machine travel speed and incorporates a kickdown pedal to select first gear. The operator may use the Autoshift in manual mode when operator control of shift points is desired. The JCB Powershift transmission allows fast gear changing without losing speed or momentum on gradients. The integral torque converter and electrically operated reversing shuttle help this backhoe loader produce fast cycle times for real wheeled loader performance. Low 1st and 2nd gear ratios provide excellent tractive effort for loading and sitedripping. JCB transmissions feature a (SAHR) clutch park brake, hydraulic release, spring engaged.

Machine model	3CX Super, 3CX Super Sitemaster		3CX, 3CX Sitemaster, 3CX Contractor		3CX Contractor
Manufacturer	JCB	JCB	JCB	JCB	JCB
Type	Syncroshuttle	Powershift	Syncroshuttle	Powershift	Autoshift
Torque converter	305mm	305mm	305mm	305mm	305mm
Torque converter ratio	2.54:1	2.54:1	2.54:1	2.54:1	2.54:1
Torque Lock	N/A	Option	N/A	Standard	Option
Gears forward/reverse	4/4	4/4	4/4	4/4	6/4
Gear selection	Manual	Powershift	Manual	Powershift	Powershift
Shuttle control – F/R	Power shuttle	Power shuttle	Power shuttle	Power shuttle	Power shuttle
Travel speeds	kph	kph	kph	kph	kph
Tyres equipped	16.9x24 Goodyear Sure Grip		F: 12.5x18 R: 18.4x26 T219 JCB SM		F: 12.5x18 R: 18.4x26 T219 JCB SM
Gear 1	5.1	4.9	5.8	5.4	5.1
Gear 2	8.3	8.6	9.4	10.0	8.6
Gear 3	17.7	19.8	20.2	22.5	11.6
Gear 4	36.7	36.7	41.8	41.8	18.7
Gear 5	–	–	–	–	31.1
Gear 6	–	–	–	–	41.8

\* Based on 100% efficiency at 2200rpm.

## FRONT AXLE

JCB front axles are designed and built specifically for backhoe loaders and accept a wide variety of tyre combinations.

Machine model	3CX 2WD	3CX 4WD, 3CX Contractor, 3CX Sitemaster	3CX Super, 3CX Super Sitemaster
Type	Flame cut bar	JCB steer drive with torque proportional	JCB 4WD steer drive with torque proportional
Axle ratings	kg	kg	kg
Static load rating	16500	16500	25000
Dynamic load rating	8300	8300	12500
Oscillation angle	16°	16°	16°
Steering ram	Powered track rod	Powered track rod	Powered track rod

## REAR AXLE

JCB rear axles are designed and built specifically for backhoe loaders and accept a wide variety of tyre combinations.

Machine model	3CX, 3CX Contractor, 3CX Sitemaster	3CX Super, 3CX Super Sitemaster
Type	JCB epicyclic hub reduction with torque proportional	JCB 4WD steer drive with torque proportional
Limited Slip	Option	Option
Axle ratings	kg	kg
Static load rating	25000	25000
Dynamic load rating	12500	12500
Steering ram	Powered track rod	Powered track rod

## STEERING

Full power hydrostatic system utilising the main hydraulic pump via a steering priority valve. In the event of engine failure, emergency steering is maintained.

Machine model	3CX, 3CX Sitemaster, 3CX Contractor	3CX Super, 3CX Super Sitemaster
Axles	Steer drive	Steer drive
Steering turns – lock to lock	2¾	2¾
	m	m
Kerb – kerb turning circle – unbraked	8.1	9.35
Loader clearance circle – unbraked	10.4	11.15
Kerb – kerb turning circle – braked	6.9	8.0
Loader clearance circle – braked	9.5	9.5

(Depending on tyre size, ground conditions etc.)

## TYRES

	3CX, Sitemaster	Contractor	Super, Super Sitemaster
Front	12.5 x 18 x 10 Traction or Industrial	16 x 20, 10PR Traction or Industrial	14.9/14 x 24, 12PR Industrial
	400/70 R18 Traction or Industrial	400/70 R20 Traction or Industrial	16.9/14 x 24, 12PR Industrial
	340/80 R18 Traction	12.5 x 20 x 10 Industrial	460/70 x 24, Radial Traction
Rear	16.9 x 28, 12PR Traction or Industrial	18.4 x 26, 12PR Traction or Industrial	14.9/14 x 24, 12PR Industrial
	18.4 x 26, 12PR Traction or Industrial	19.5L – R28 Traction	16.9/14 x 24, 12PR Industrial
	440/80 R28, Traction	500/70 R28 Traction	460/70 x 24, Radial Traction
	480/80 x R26, Radial Industrial		

## HYDRAULIC SYSTEM

Open centre systems (piston pump) @ 2200rpm	l/min
Manual & EasyControl	165
Closed centre systems (piston pump) @ 2200rpm	l/min
Advanced EasyControl	165
	bar
System relief pressure	251

## SERVICE CAPACITIES

Machine model	All models
	ltr
Cooling system	18.5
Fuel tank	160
Engine oil with filter	15
Gearbox with filter	16
Rear axle	16
Front drive axle	16
Hydraulic system incl. tank	117

## OPTIONAL ACCESSORIES

Key/keypad immobiliser, Sitemaster, Michelin or Goodyear Brands of tyres with a selection of traction/industrial tread in a crossply/radial construction, Powershift/Autoshift transmissions, JCB TorqueLock, JCB Powerslide, Standard excavator buckets (300mm to 900mm), Deep profile excavator buckets (300mm to 940mm), Ditching buckets, General purpose/6-in-1 front shovels, Manual/hydraulic front quickhitch, Manual/hydraulic rear quickhitch, 3/8" loader arm pipework/5/8" loader arm pipework, Hammer/bi-directional pipework, Hand held tool circuit, 9m hose reel, Excavator lifting kits for EN474 and non-EN474 territories, Loader/excavator HBCV's, Electric refuelling pump, Heated front screen, Reverse alarm, Coffee machine, Grid heaters, Eberspacher cold start kits, Front bumper protection, Fire extinguisher, Fuel tank guards, Air suspension seat, Seat headrest, Biodegradable oil, Black/yellow trim kits, Instrument panel vandal guard, Different size front counterweights, Stabiliser streetpads, Shovel streetpads, Rear light guards, Lubricity filter, Shovel clam ram guards, Dual pattern controls (ISO/SAE changeover), Extendable steer column, Air conditioning, SRS.

## LOADER DIMENSIONS – 3CX, 3CX Contractor, 3CX Sitemaster

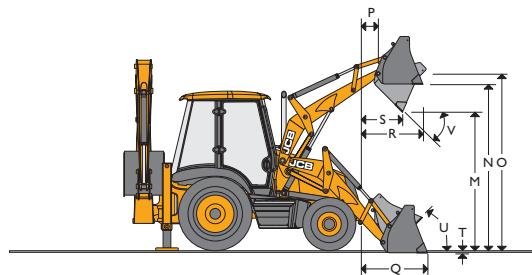

## LOADER DIMENSIONS – 3CX, 3CX Contractor, 3CX Sitemaster

	GP shovel	6-in-1 shovel
	m	m
M Dump height	2.74	2.72
N Load over height	3.23	3.20
O Loader hinge pin height	3.45	3.45
P Pin forward reach	0.36	0.36
Q Reach at ground (toe plate horizontal)	1.42	1.37
R Max. reach at full height	1.20	1.15
S Reach at full height fully dumped	0.83	0.78
T Dig depth	0.07	0.10
U Roll back at ground	45°	45°
V Dump angle	43°	43°
Jaw opening width	–	0.95

## LOADER DIMENSIONS – 3CX Super, 3CX Super Sitemaster

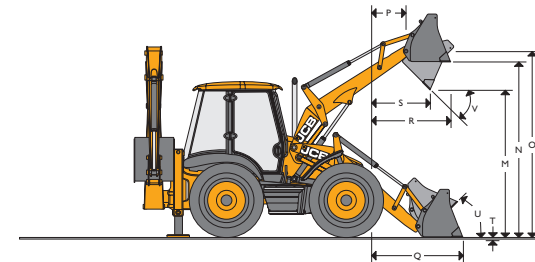

## LOADER DIMENSIONS – 3CX Super, 3CX Super Sitemaster

	GP shovel	6-in-1 shovel
	m	m
M Dump height	2.64	2.64
N Load over height	3.16	3.13
O Pin height	3.41	3.41
P Pin forward reach	0.47	0.47
Q Reach at ground (toe plate horizontal)	1.52	1.50
R Max. reach at full height	1.26	1.22
S Reach at full height fully dumped	0.88	0.82
T Dig depth	0.18	0.23
U Rollback at ground	45°	45°
V Dump angle	44°	44°
Jaw opening width	–	0.95

**LOADER PERFORMANCE**

	3CX	3CX	3CX Super, 3CX Super Sitemaster
	kgf	kgf	kgf
Shovel type	GP shovel	6 in l	6 in l
Loader breakout – shovel	6170	6531	6590
Loader breakout – arms	4942	4732	5730
Rated operating capacity 7'4"*	3479	3229	4378
Rated operating capacity 7'8"*	3439	3169	–
Clamping force	–	2940	2945
	3CX Super	3CX Sitemaster, 3CX Contractor (Standard lift)	3CX Contractor (Heavy lift)
Shovel type	GP shovel	6 in l	6 in l
Loader breakout – shovel	6227	6531	6531
Loader breakout – arms	5936	4732	6203
Max. lift capacity 7'4"	4638	3229	4308
Max. lift capacity 7'8"	–	3169	4248
Clamping force	–	2940	2940

\*Rated operating capacity as determined according to ISO 14397 : 2007.

**LOADER ATTACHMENTS – Direct Mount – All models**

Loader buckets are listed according to size and application. All buckets are drilled to accept optional auxiliary cutting edge or teeth. Flat top box section provides rigidity and assists in bucket levelling.

Width mm	Capacity SAE	
	Rated m <sup>3</sup>	Struck m <sup>3</sup>
	GP shovel	
2235	1.0	0.83
2350	1.1	0.91
	6-in-l shovel	
2235	1.0	0.76
2350	1.2	1.02

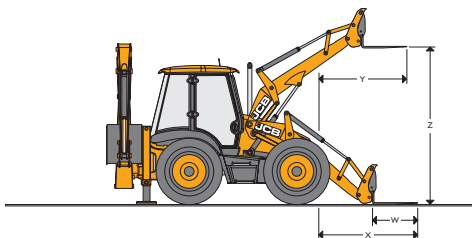
**LOADER ATTACHMENTS**

**LOADER DIMENSIONS – Forklift Performance Data – 3CX, 3CX Contractor, 3CX Sitemaster**

	6-in-l shovel mounted forks	Quickhitch mounted forks
	m	m
W Forks – tine length	1.1	1.1
Forks – tine width	0.08	0.08
X Forks reach at ground level	2.66	2.03
Y Forks reach at full height	2.25	1.72
Z Forks lift height – max.	2.92	3.27
Fork spacing – min	0.2	0.2
Fork spacing – max	2.17	1.03
SWL @ 500mm load centres	kg 1000	2000

**LOADER ATTACHMENTS – Forklift Performance and Data – 3CX Super, 3CX Super Sitemaster**

	6-in-l Shovel mounted forks	Quickhitch mounted forks
	m	m
W Fork length	1.1	1.1
Section width	0.08	0.08
X Reach at ground	2.78	2.18
Y Reach at full height	2.38	1.81
Z Fork lift height	2.85	3.23
Fork spacing – min	0.2	0.2
Fork spacing – max	2.17	1.03
SWL @ 500mm load centres	kg 1000	2000

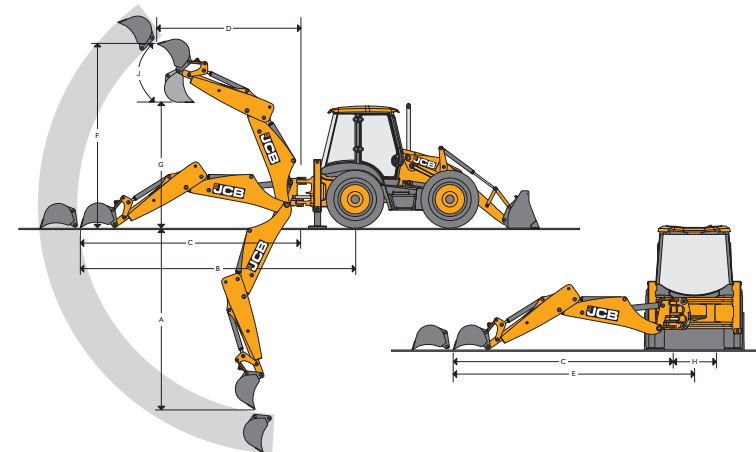
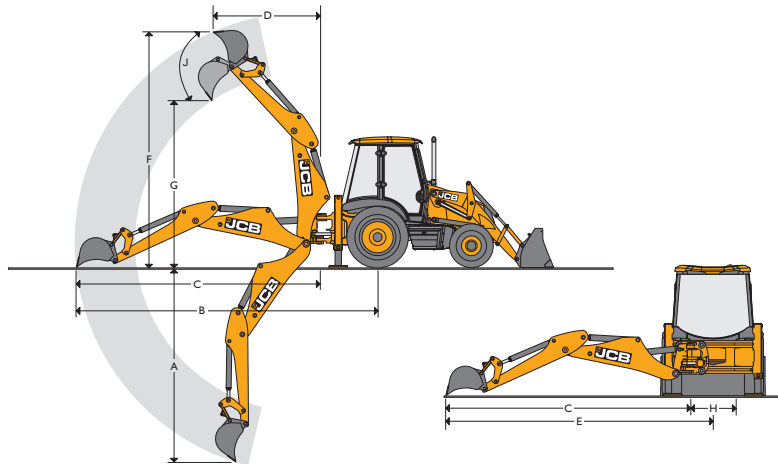
Integrated Quickhitch and Forks are unique to JCB and speeds up attachment changeover times and increases productivity. Mechanical or hydraulic Quickhitch versions are available and with the shovel removed, the flip over forks maximise fork lift capacity to 2000kg and increases visibility to the load.



## BACKHOE DIMENSIONS

Model		3CX	
		3CX	3CX Sitemaster 3CX Contractor
		Standard Dipper	Extradig
		m	m
A SAE max dig depth	Ext	–	5.46
	Ret	4.24	4.24
SAE 2ft flat bottom	Ext	–	5.43
	Ret	4.21	4.21
Maximum dig depth with deep profile bucket	Ext	–	5.97
	Ret	4.75	4.75
B Reach – ground level to rear wheel centre	Ext	–	7.87
	Ret	6.72	6.72
C Reach – ground level to slew centre	Ext	–	6.52
	Ret	5.37	5.37
D Reach – at full height to slew centre	Ext	–	3.66
	Ret	2.74	2.74
E Side reach – to centre line of machine	Ext	–	7.09
	Ret	5.94	5.94
F SAE operating height	Ext	–	6.35
	Ret	5.53	5.53
G Maximum loadover height	Ext	–	4.72
	Ret	3.84	3.84
SAE loadover height	Ext	–	4.32
	Ret	3.4	3.4
H Total kingpost travel		1.16	1.16
Narrow rear frame option		1.05	1.05
J Bucket rotation	Speed	201°	201°

## BACKHOE DIMENSIONS

Model		3CX Super		3CX Super & 3CX Super Sitemaster	
		Standard dipper		Extradig	
		m		m	
A SAE max dig depth	Ext	–	–	5.58	5.58
	Ret	4.37	–	4.37	4.37
SAE 2ft flat bottom	Ext	–	–	5.55	5.55
	Ret	4.34	–	4.34	4.34
Maximum dig depth with deep profile bucket	Ext	–	–	5.93	5.93
	Ret	4.72	–	4.72	4.72
B Reach – ground level to rear wheel centre	Ext	–	–	7.88	7.88
	Ret	6.74	–	6.74	6.74
C Reach – ground level to slew centre	Ext	–	–	6.54	6.54
	Ret	5.40	–	5.40	5.40
D Reach – at full height to slew centre	Ext	–	–	3.75	3.75
	Ret	2.82	–	2.82	2.82
E Side reach – to centre line of machine	Ext	–	–	7.09	7.09
	Ret	5.94	–	5.94	5.94
F SAE operating height	Ext	–	–	6.20	6.20
	Ret	5.39	–	5.39	5.39
G Maximum loadover height	Ext	–	–	4.67	4.67
	Ret	3.78	–	3.78	3.78
SAE loadover height	Ext	–	–	4.22	4.22
	Ret	3.33	–	3.33	3.33
H Total kingpost travel		1.05	–	1.05	1.05
J Bucket rotation	Speed	201°	–	201°	201°

**BACKHOE PERFORMANCE – 3CX, 3CX Sitemaster, 3CX Super, 3CX Super Sitemaster**

		Standard Dipper	Extradig
		kgf	kgf
Bucket tearout	Speed	5431	5385
	Power	6324	6228
Dipper tearout	Ext	–	2255
	Ret	3217	3225
Lift capacity of bucket pivot at full reach		kg	kg
	Ext	–	719
	Ret	1584	1451

**BACKHOE PERFORMANCE – 3CX Contractor**

		kgf
		Speed
Bucket tearout	Power	6228
	Ext	2255
Dipper tearout – standard lift excavator	Ret	3225
	Ext	2729
Dipper tearout – heavy lift excavator	Ret	3903
	Ext	719
Lift capacity of bucket pivot at Full reach – standard lift excavator	Ret	1451
Lift capacity of bucket pivot at full reach – heavy lift excavator		kg
	Ext	1082
	Ret	1885

**BACKHOE ATTACHMENTS – Standard Profile Bucket**

Width*	Capacity SAE		Weight (+ Teeth)	
	Rated m <sup>3</sup>	Struck m <sup>3</sup>	kg	Teeth
mm				
229	0.04	0.03	95	0
305 †	0.06	0.05	102	3
356 †	0.075	0.06	105	3
400 †	0.09	0.07	109	3
457 †	0.12	0.09	116	3
610 †	0.17	0.13	140	4
800 †	0.24	0.17	162	5
950 †	0.30	0.21	198	5

\* Including sidecutters. Width less sidecutters deduct 25mm.

† Available with additional wear strips to give added strength and rigidity.

**BACKHOE ATTACHMENTS – Deep Profile Bucket**

Width*	Capacity SAE		Weight (+ Teeth)	
	Rated m <sup>3</sup>	Struck m <sup>3</sup>	kg	Teeth
mm				
305	0.09	0.07	102	3
356	0.11	0.09	117	3
457	0.16	0.13	122	3
610	0.23	0.18	142	4
800	0.30	0.24	163	5
950	0.38 †	0.30	183	5
1100	0.48 †	0.34	203	6

\* Including sidecutters. Width less sidecutters deduct 25mm (1in). † Capacity in cu.yd.

**DITCHING BUCKETS**

Width*	Capacity SAE		Weight
	Rated m <sup>3</sup>	Struck m <sup>3</sup>	kg
mm			
1525	0.22	0.155	150
1830	0.26	0.186	172

**TAPERED BUCKETS**

Width*	Capacity SAE		Angle degrees	Teeth
	Rated m <sup>3</sup>	Struck m <sup>3</sup>		
mm				
381–1676	0.07	0.06	30	2
305–1067	0.12	0.10	60	2